

INTERNATIONAL STANDARD

IEC
60939-2

Second edition
2005-02

Passive filter units for electromagnetic interference suppression –

Part 2: Sectional specification – Passive filter units for which safety tests are appropriate – Test methods and general requirements



Reference number
IEC 60939-2:2005(E)

Publication numbering

As from 1 January 1997 all IEC publications are issued with a designation in the 60000 series. For example, IEC 34-1 is now referred to as IEC 60034-1.

Consolidated editions

The IEC is now publishing consolidated versions of its publications. For example, edition numbers 1.0, 1.1 and 1.2 refer, respectively, to the base publication, the base publication incorporating amendment 1 and the base publication incorporating amendments 1 and 2.

Further information on IEC publications

The technical content of IEC publications is kept under constant review by the IEC, thus ensuring that the content reflects current technology. Information relating to this publication, including its validity, is available in the IEC Catalogue of publications (see below) in addition to new editions, amendments and corrigenda. Information on the subjects under consideration and work in progress undertaken by the technical committee which has prepared this publication, as well as the list of publications issued, is also available from the following:

- **IEC Web Site (www.iec.ch)**
- **Catalogue of IEC publications**

The on-line catalogue on the IEC web site (www.iec.ch/searchpub) enables you to search by a variety of criteria including text searches, technical committees and date of publication. On-line information is also available on recently issued publications, withdrawn and replaced publications, as well as corrigenda.
- **IEC Just Published**

This summary of recently issued publications (www.iec.ch/online_news/justpub) is also available by email. Please contact the Customer Service Centre (see below) for further information.
- **Customer Service Centre**

If you have any questions regarding this publication or need further assistance, please contact the Customer Service Centre:

Email: custserv@iec.ch
Tel: +41 22 919 02 11
Fax: +41 22 919 03 00

INTERNATIONAL STANDARD

IEC 60939-2

Second edition
2005-02

Passive filter units for electromagnetic interference suppression –

Part 2: Sectional specification – Passive filter units for which safety tests are appropriate – Test methods and general requirements

© IEC 2005 — Copyright - all rights reserved

No part of this publication may be reproduced or utilized in any form or by any means, electronic or mechanical, including photocopying and microfilm, without permission in writing from the publisher.

International Electrotechnical Commission, 3, rue de Varembé, PO Box 131, CH-1211 Geneva 20, Switzerland
Telephone: +41 22 919 02 11 Telefax: +41 22 919 03 00 E-mail: inmail@iec.ch Web: www.iec.ch



Commission Electrotechnique Internationale
International Electrotechnical Commission
Международная Электротехническая Комиссия

PRICE CODE

X

For price, see current catalogue

CONTENTS

FOREWORD.....	4
1 General.....	6
1.1 Scope.....	6
1.2 Normative references	6
1.3 Information to be given in a detail specification	7
1.4 Definitions	8
1.5 Marking	9
2 Preferred ratings and characteristics	10
2.1 Preferred characteristics	10
2.2 Preferred values of ratings	10
3 Quality assessment procedures.....	11
3.1 Primary stage of manufacture.....	11
3.2 Structurally similar filters	11
3.3 Certified records of released lots	11
3.4 Approval testing	11
3.5 Quality conformance inspection.....	13
4 Test and measurement procedures.....	18
4.1 Earth inductors incorporated in filters	18
4.2 Capacitance and tan δ measurements	18
4.3 Visual examination and check of dimensions	18
4.4 Voltage proof.....	19
4.5 Insulation resistance	20
4.6 DC line resistance or voltage drop at rated current.....	20
4.7 Insertion loss.....	21
4.8 Discharge resistance.....	21
4.9 Robustness of terminations	22
4.10 Resistance to soldering heat	22
4.11 Solderability	22
4.12 Rapid change of temperature	22
4.13 Vibration.....	23
4.14 Bump	23
4.15 Shock.....	24
4.16 Container sealing	24
4.17 Climatic sequence	25
4.18 Damp heat, steady state.....	26
4.19 Temperature rise.....	26
4.20 Impulse voltage	28
4.21 Endurance.....	29
4.22 Charge and discharge	31
4.23 Passive flammability.....	32
4.24 Current overload	32
4.25 Solvent resistance of the marking.....	32
4.26 Component solvent resistance.....	33
4.27 Active flammability	33

Annex A (normative) Test schedule for qualification approval – Assessment level D / DZ	34
Annex B (normative) Test schedule for safety requirements only	38
Annex C (normative) Circuit for the impulse voltage test	40
Annex D (normative) Circuit for the endurance test	42
Annex E (normative) Declaration of design	43
Figure 1 – Impulse wave form	29
Figure C.1 – Impulse voltage test circuit	40
Table 1 – Classification of class X capacitors	8
Table 2 – Classification of class Y capacitors	9
Table 3 – Tests concerning safety requirements only	14
Table 4 – Sampling plan – Safety and performance tests qualification approval – Assessment level D / DZ	15
Table 5 – Lot-by-lot-tests – Assessment level D / DZ	16
Table 6 – Lot-by-lot test – Safety tests only approval	16
Table 7 – Periodic tests – Assessment level D / DZ	17
Table 8 – Creepage distances and clearances	18
Table 9 – Voltage proof	19
Table 10 – Insulation resistance	20
Table 11 – Preferred severities	24
Table 12 – Measurements and requirements after charge and discharge	31
Table A.1 – Test schedule for qualification approval – Assessment level D / DZ	34
Table B.1 – Test schedule for safety requirements only	38
Table C.1 – Values of C_X , C_T , R_P , R_S , C_P	40
Table C.2 – Values and tolerances of C_X , t_r , t_d	41

INTERNATIONAL ELECTROTECHNICAL COMMISSION

**PASSIVE FILTER UNITS FOR ELECTROMAGNETIC
INTERFERENCE SUPPRESSION –**
**Part 2: Sectional specification –
Passive filter units for which safety tests are appropriate –
Test methods and general requirements**

FOREWORD

- 1) The International Electrotechnical Commission (IEC) is a worldwide organization for standardization comprising all national electrotechnical committees (IEC National Committees). The object of IEC is to promote international co-operation on all questions concerning standardization in the electrical and electronic fields. To this end and in addition to other activities, IEC publishes International Standards, Technical Specifications, Technical Reports, Publicly Available Specifications (PAS) and Guides (hereafter referred to as "IEC Publication(s)"). Their preparation is entrusted to technical committees; any IEC National Committee interested in the subject dealt with may participate in this preparatory work. International, governmental and non-governmental organizations liaising with the IEC also participate in this preparation. IEC collaborates closely with the International Organization for Standardization (ISO) in accordance with conditions determined by agreement between the two organizations.
- 2) The formal decisions or agreements of IEC on technical matters express, as nearly as possible, an international consensus of opinion on the relevant subjects since each technical committee has representation from all interested IEC National Committees.
- 3) IEC Publications have the form of recommendations for international use and are accepted by IEC National Committees in that sense. While all reasonable efforts are made to ensure that the technical content of IEC Publications is accurate, IEC cannot be held responsible for the way in which they are used or for any misinterpretation by any end user.
- 4) In order to promote international uniformity, IEC National Committees undertake to apply IEC Publications transparently to the maximum extent possible in their national and regional publications. Any divergence between any IEC Publication and the corresponding national or regional publication shall be clearly indicated in the latter.
- 5) IEC provides no marking procedure to indicate its approval and cannot be rendered responsible for any equipment declared to be in conformity with an IEC Publication.
- 6) All users should ensure that they have the latest edition of this publication.
- 7) No liability shall attach to IEC or its directors, employees, servants or agents including individual experts and members of its technical committees and IEC National Committees for any personal injury, property damage or other damage of any nature whatsoever, whether direct or indirect, or for costs (including legal fees) and expenses arising out of the publication, use of, or reliance upon, this IEC Publication or any other IEC Publications.
- 8) Attention is drawn to the Normative references cited in this publication. Use of the referenced publications is indispensable for the correct application of this publication.
- 9) Attention is drawn to the possibility that some of the elements of this IEC Publication may be the subject of patent rights. IEC shall not be held responsible for identifying any or all such patent rights.

International Standard IEC 60939-2 has been prepared by IEC technical committee 40: Capacitors and resistors for electronic equipment.

This second edition cancels and replaces the first edition published in 1988. This second edition constitutes a technical revision.

The major changes that have been made between the first and the second edition are :

- Capacitance and $\tan \delta$ measurements, d.c. line resistance or voltage drop at rated current, impulse voltage, passive flammability, current overload, solvent resistance of marking, component solvent resistance and active flammability have been added to Clause 4, test and measurement procedures.

The text of this standard is based on the following documents:

FDIS	Report on voting
40/1510/FDIS	40/1537/RVD

Full information on the voting for the approval of this standard can be found in the report on voting indicated in the above table.

This publication has been drafted in accordance with the ISO/IEC Directives, Part 2.

IEC 60939 consists of the following parts, under the general title *Passive filter units for electromagnetic interference suppression*

- Part 1: Generic specification
- Part 2: Sectional specification: Test methods and general requirements
- Part 2-1: Blank detail specification – Passive filter units for electromagnetic interference suppression – Filters for which safety tests are required (Assessment level D / DZ)
- Part 2-2: Blank detail specification – Passive filter units for electromagnetic interference suppression – Filters for which safety tests are required (Safety tests only)

The committee has decided that the contents of this publication will remain unchanged until the maintenance result date indicated on the IEC web site under "<http://webstore.iec.ch>" in the data related to the specific publication. At this date, the publication will be

- reconfirmed;
- withdrawn;
- replaced by a revised edition, or
- amended.

The contents of the corrigendum of November 2005 have been included in this copy.

A bilingual version of this publication may be issued at a later date.

PASSIVE FILTER UNITS FOR ELECTROMAGNETIC INTERFERENCE SUPPRESSION –

Part 2: Sectional specification – Passive filter units for which safety tests are appropriate – Test methods and general requirements

1 General

1.1 Scope

This Sectional specification applies to passive filter units for electromagnetic interference suppression which fall within the scope of the Generic Specification IEC 60939-1.

The scope of this Sectional specification is restricted to passive filter units for which safety tests are appropriate. This implies that filters specified according to this Sectional specification will either be connected to mains supplies, when compliance with the mandatory tests of Table 3 is necessary, or used in other circuit positions where the equipment specification prescribes that some or all of these safety tests are required.

This Sectional specification applies to passive filter units which will be connected to an a.c. mains or other supply with a nominal voltage not exceeding 1 000 V a.c., with a nominal frequency not exceeding 400 Hz, or 1 000 V d.c.

1.2 Normative references

The following referenced documents are indispensable for the application of this document. For dated references, only the edition cited applies. For undated references, the latest edition of the referenced document (including any amendments) applies.

NOTE Components other than inductors and capacitors in the filter unit should fulfil requirements in the relevant IEC Standard.

IEC 60060-1, *High-voltage test techniques – Part 1: General definitions and test requirements*

IEC 60062, *Marking codes for resistors and capacitors*

IEC 60068-1, *Environmental testing – Part 1: General and guidance*

IEC 60068-2-17, *Basic environmental testing procedures – Part 2: Tests – Test Q: Sealing*

IEC 60085, *Thermal evaluation and classification of electrical insulation*

IEC 60335-1, *Safety of household and similar electrical appliances – Part 1: General requirements*

IEC 60384-9, *Fixed capacitors for use in electronic equipment – Part 9: Sectional specification: Fixed capacitors of ceramic dielectric, Class 2*

IEC 60384-14, *Fixed capacitors for use in electronic equipment – Part 14: Sectional specification: Fixed capacitors for electromagnetic interference suppression and connection to the supply mains*

IEC 60664 (all parts), *Insulation coordination for equipment within low-voltage systems*

IEC 60938-1, *Fixed inductors for electromagnetic interference suppression – Part 1: Generic specification*

IEC 60939-1, *Passive filter units for electromagnetic interference suppression – Part 1: Generic specification*

IEC 60940, *Guidance information on the application of capacitors, resistors, inductors and complete filter units for radio interference suppression*

IEC 61140, *Protection against electric shock – Common aspects for installation and equipment*

1.3 Information to be given in a detail specification

1.3.1 General

The detail specifications shall be derived from the relevant blank detail specification.

Detail specifications shall not specify requirements inferior to those of the generic, sectional or blank detail specification. When more severe requirements are included, they shall be listed in 1.9 of the detail specification, and indicated in the test schedules, for example by an asterisk.

NOTE The information given in 1.3.2 may, for convenience, be presented in tabular form.

The following information shall be given in each detail specification and the values quoted shall preferably be selected from the appropriate clause of this sectional specification.

1.3.2 Outline drawing and dimensions

There shall be an illustration of the filter as an aid to easy recognition and for comparison of the filter with others. Dimensions and their associated tolerances, which affect interchangeability and mounting, shall be given in the detail specification. All dimensions shall preferably be stated in millimetres.

Normally, the numerical values shall be given for the length of the body, the width and height of the body and the wire spacing, or for cylindrical types, the body diameter and the length and diameter of the terminations. When necessary, for example when a range of filters is covered by a single detail specification, their dimensions and their associated tolerances shall be placed in a table following the drawing.

In addition, the detail specification shall state such other dimensional information as will adequately describe the filter outline.

1.3.3 Mounting

The detail specification shall specify the method of mounting recommended for normal use and the method which is mandatory for the application of the vibration, bump, shock and endurance tests. The design of the filter may be such that special mounting fixtures or heat sinks are required in its use. In this case, the detail specification shall describe the mounting fixtures and they shall be used in the application of the vibration, bump or shock tests. The specified heat sink shall be used in the application of the endurance test.

If recommendations for mounting for "normal" use are made, they shall be included in the detail specification under 1.8 "Additional information (not for inspection purposes)". If they are included, a warning can be given that the full vibration, bump and shock performance may not be available if mounting methods other than those specified in 1.1 of the detail specification are used.

1.3.4 Ratings and characteristics

1.3.4.1 General

The ratings and characteristics shall be in accordance with the relevant clauses of this specification.

1.3.4.2 Particular characteristics

Additional characteristics may be listed when they are considered necessary to specify adequately the filter for design or application purposes.

1.3.5 Marking

The detail specification shall specify the content of the marking on the filter and the package.

1.4 Terms and definitions

For the purposes of this Sectional specification, the terms and definitions given in 2.2 of IEC 60939-1, as well as the following apply.

1.4.1

a.c. mains filter (or mains filter)

passive filter unit designed essentially for application with a power-frequency alternating voltage supplied from the mains

1.4.2

class X capacitor

capacitor of a type suitable for use in situations where failure of the capacitor would not lead to danger of electric shock but could result in a risk of fire.

Class X capacitors are divided into three subclasses (see Table 1) according to the peak voltage of the impulses superimposed on the mains voltage to which they may be subjected in service. Such impulses may arise from lightning strikes on outside lines, from switching in neighbouring equipment, or switching in the equipment in which the capacitor is used.

Table 1 – Classification of class X capacitors

Subclass	Peak pulse voltage in service	IEC 60664 insulation category	Application	Peak impulse voltage U_p applied before endurance test
X1	> 2,5 kV ≤ 4,0 kV	III	High pulse application	when $C_R \leq 1,0 \mu\text{F}$: $U_p = 4,0 \text{ kV}$ when $C_R > 1,0 \mu\text{F}$: $U_p = \frac{4}{\sqrt{C_R \times 10^6}} \text{ kV}$
X2	≤ 2,5 kV	II	General purpose	when $C_R \leq 1,0 \mu\text{F}$: $U_p = 2,5 \text{ kV}$ when $C_R > 1,0 \mu\text{F}$: $U_p = \frac{2,5}{\sqrt{C_R \times 10^6}} \text{ kV}$
X3	≤ 1,2 kV	-	General purpose	none

1.4.3**class Y capacitor**

capacitor or RC-unit of a type suitable for use in situations where failure of the capacitor could lead to danger of electric shock.

Class Y capacitors are further divided into four subclasses Y1, Y2, Y3 and Y4, as shown in Table 2.

(IEC 60384-14, 1.5.4)

Table 2 – Classification of class Y capacitors

Subclass	Type of insulation bridged	Range of rated voltages	Peak impulse voltage before endurance test
Y1	Double insulation or reinforced insulation	≤ 500 V	8,0 kV
Y2	Basic insulation or supplementary insulation	≥ 150 V ≤ 300 V	5,0 kV
Y3		≥ 150 V ≤ 250 V	none
Y4		< 150 V	2,5 kV
NOTE For definitions of basic, supplementary, double and reinforced insulation, see IEC 61140.			

One Y-capacitor may bridge basic insulation. One Y-capacitor may bridge supplementary insulation. If combined basic and supplementary insulations are bridged by two Y2-, Y3- or Y4-capacitors in series, they must have the same nominal value.

For guidance on the application of capacitors bridging basic insulation, see 6.1 of IEC 60940.

1.4.4**earth inductor**

inductor that forms part of the earth lead of a filter

1.5 Marking

1.5.1 See 2.4 of IEC 60939-1 with the following details:

The information given in the marking is normally selected from the following list; the relative importance of each item is indicated by its position in the list:

- a) manufacturer's name or trademark;
- b) manufacturer's type designation or the type designation given in the detail specification;
- c) recognised approval mark;
- d) rated voltage and rated frequency;
- e) identification of terminations and/or circuit diagram;
- f) rated current;
- g) rated temperature;
- h) climatic category;
- i) year and month (or week) of manufacture (if the indication is in code, it shall be the code given in IEC 60062);
- j) reference to the detail specification.

1.5.2 The filter shall be clearly marked with the information in 1.5.1 a), b), c), d) and f), and also e) if this is not implied by b).

1.5.3 The package containing the filter(s) shall be clearly marked with all the information listed in 1.5.1.

National approvals may be indicated by lettering as an alternative to the approval mark.

1.5.4 Any additional marking shall be so applied that no confusion can arise.

2 Preferred ratings and characteristics

2.1 Preferred characteristics

2.1.1 General

The values given in detail specifications should preferably be selected from the following:

2.1.2 Preferred climatic categories

The filters covered by this specification are classified into climatic categories according to the general rules given in IEC 60068-1.

The lower and upper category temperature and the duration of the damp heat, steady state test should be chosen from the following:

Lower category temperature: –65 °C, –55 °C, –40 °C, –25 °C or –10 °C;

Upper category temperature: +70 °C, +85 °C, +100 °C, +125 °C or +155 °C;

Duration of the damp heat, steady state test: 21 or 56 days.

The severities for the cold and dry heat tests are the lower and upper category temperatures respectively.

For guidance on the application of the categories described above, see IEC 60940.

2.2 Preferred values of ratings

2.2.1 Rated voltage (U_R)

The preferred values of rated voltage are:

115 V, 125 V, 250 V, 400 V, 440 V, 500 V and 760 V.

Electromagnetic interference suppression filters shall be chosen to have a rated voltage equal to or greater than the nominal voltage of the supply system to which they are connected. The design of the filters shall take into account the possibility that the voltage of the system may rise by up to 10 % above its nominal voltage.

NOTE X-capacitors can be used in a star connect.

2.2.2 Category voltage (U_C)

The category voltage is equal to the rated voltage unless otherwise stated in the detail specification.

2.2.3 Rated temperature

The rated temperature shall not be less than +40 °C.

2.2.4 Passive flammability

When specified, the minimum category of passive flammability permitted is category C.

3 Quality assessment procedures

3.1 Primary stage of manufacture

See 3.2 of IEC 60939-1.

3.2 Structurally similar filters

See 3.4 of IEC 60939-1.

In addition to these provisions, filters may be considered as structurally similar only when for their range of component values they have the same capacitor, inductor and resistor technologies and corresponding capacitive elements are of the same subclass.

3.3 Certified records of released lots

The information required in 3.5.1 of IEC 60939-1 shall be made available when prescribed in the detail specification and when requested by a customer. After the endurance test, the parameters for which variables information is required are insertion loss change and insulation resistance.

3.4 Approval testing

3.4.1 Safety tests only approval

Table 3 and Annex B form a schedule limited to tests concerning safety only requirements. The schedule to be used for safety only approval will be on the basis of fixed sample sizes according to 3.4 of IEC 60939-1 as given in 3.4.3 and Table 3 of this Sectional specification. Prior to the approval testing being carried out, it is necessary to submit to the certification body a declaration of design (Annex E) registering essential data and basic design details of the passive filters for which approval is sought.

If subsequent to the granting of approval, any component is changed, the certification body shall be informed (see Annex E). Extension of approval to include changed component(s) is at the discretion of the certification body.

3.4.2 Qualification approval

Tables 4, 5, 6 and 7 are to be used when qualification approval is sought.

The procedures for qualification approval testing are given in 3.5 of IEC 60939-1. The schedule to be used for qualification approval testing on the basis of lot-by-lot and periodic tests is given in 3.5 and Tables 5, 6 and 7 of this Sectional specification. The procedure using a fixed sample size schedule is given in 3.4.3 and Table 4. For the two procedures, the sample sizes and the number of non-conforming items shall be of comparable order. The test conditions and requirements shall be the same. Qualification approval according to the fixed sample sizes of Table 4 is preferred.

3.4.3 Sampling

Filter types to be qualified together shall have the same rated voltage, and combination of component technologies; in addition, the corresponding capacitive elements shall be of the same subclass. The numbers of filters required for each qualification in each group are given in Tables 3 and 4.

For each qualification, the sample shall contain equal numbers of specimens of the highest and lowest total capacitance values in the range to be qualified. Where only one total capacitance value is involved, the total number of filters as stated in Tables 3 and 4 shall be tested.

If, for a given value of total capacitance, there is more than one rated current available in the range, then filters with the highest rated current shall be chosen. If at this rated current more than one inductance value is available in the range, then filters with the highest inductance value shall be chosen.

NOTE "Total capacitance" in the paragraph above means the capacitance between the input terminations of the filter.

Spare specimens are permitted as follows:

- a) one per value which may be used to replace the non-conforming item in group 0;
- b) one per value which may be used as replacements for non-conforming specimens because of incidents not attributable to the manufacturer;
- c) sufficient specimens to enable the repeat test of Note 8 to Tables 7 to be carried out.

The numbers given in Group 0 assume that all further groups are applicable. If this is not so, the numbers may be reduced accordingly. The numbers given in Group 0 may also be reduced if, for example for expensive filters, the manufacturer chooses to carry out the tests of a number of groups in sequence on the same specimens. The numbers given for Group 0 do not include the specimens required for Groups 7 and 8.

When additional groups are introduced into the qualification approval test schedule, the number of specimens required for Group 0 shall be increased by the same number as that required for the additional groups.

Table 3 or 4 gives the number of specimens to be tested in each group together with the permissible number of non-conforming for qualification approval tests.

3.4.4 Tests

Before submission to qualification approval testing, an appropriate 100 % voltage proof test between terminations according to Table 9 shall be made. The details of this test are the prerogative of the manufacturer, but the time shall not be less than 1 s. If a d.c. test voltage is used instead of a.c. for filters containing class Y capacitors and the time is less than 2 s, it shall not be less than 1,8 times the a.c. test voltage in Table 9. All non-conforming items shall be removed from the lot prior to qualification approval testing.

One or more of the complete series of tests indicated in Table 3 or Table 4 may be required for the approval of filters covered by one detail specification. The tests of each group shall be carried out in the order given.

The whole sample with the exception of those specimens to be submitted to the tests of Groups 7 and 8 shall be subjected to the tests of Group 0 and then subdivided for the other groups.

A specimen found to be defective during the tests of group 0 shall not be used for the other groups.

"One defective" is counted when a filter has not satisfied the whole or part of the tests of a group.

The approval is granted when the number of non-conforming items does not exceed the specified number of permissible non-conforming items for each group and the total number of permissible non-conforming items.

NOTE Table 3 and Annex B or Table 4 and Annex A form the fixed sample size test schedule, where Table 3 or Table 4 includes the details for the sampling and permissible defectives for the different tests or groups of tests, whereas Annex A and Annex B together with the details of test contained in Clause 4 give a complete summary of the test conditions and performance requirements and indicate where for test methods or conditions of test a choice has to be made in the detail specification.

The conditions of test and performance requirements for the fixed sample size schedule shall be identical to those prescribed in the detail specification for the quality conformance inspection.

3.5 Quality conformance inspection

3.5.1 General

Before submission to the quality conformance inspection an appropriate 100 % voltage proof test between terminations according to Table 9 shall be made. The details of this test are the prerogative of the manufacturer, but the time shall not be less than 1 s. If a d.c. test voltage is used instead of a.c. for filters containing class Y capacitors and the time is less than 2 s, it shall not be less than 1,8 times the a.c. test voltage in Table 9. All non-conforming items shall be removed from the lot prior to lot-by-lot testing.

3.5.2 Formation of inspection lots

a) Groups A and B inspection

These tests shall be carried out on a lot-by-lot basis using sampling plans appropriate to the given assessment level specified in Table 5 and Table 6.

Manufactured lots of separately identified filter units may be aggregated into inspection lots formed for such tests as are relevant to structural similarities between those manufactured lots.

b) Group C inspection

These tests shall be carried out on a periodic basis.

Qualification approval:

These tests shall be carried out on the number of specimens appropriate to the given assessment level specified in Table 7. In order to reduce the number of specimens required to carry out any single complete periodic test, the manufacturer may elect to have the tests of more than one group carried out sequentially on the same specimens. The specimens shall be representative of the filters manufactured during each period. In subsequent periods, other filters in the approved range in production shall be tested with the aim of covering the whole range of the approval.

Safety tests only approval:

Requalification tests according to Annex B may be required by the certification body when a change of the declared design as given in Annex E is intended. The certification body will be informed about the intended change(s) and decide whether requalification tests have to be performed.

3.5.3 Test schedule

Qualification approval:

The schedule for the lot-by-lot and periodic tests for quality conformance inspection is given in Table 4a and 4b of IEC 60939-2-1.

Safety tests only approval:

The schedule for the lot-by-lot tests and criteria for requalification are given in Annex A and Annex B of IEC 60939-2-2.

3.5.4 Delayed delivery

When according to the procedures in 3.10 of IEC 60939-1, re-inspection has to be made, insulation resistance shall be checked as specified in Group A inspection and solderability shall be checked according to Group B inspection.

Table 3 – Tests concerning safety requirements only

Group	Subclauses and test	Number of specimens tested per qualification ⁴⁾	Number of permissible non-conforming items per qualification	
			Per group ⁸⁾	Total
0	4.3 Visual examinations	20/10/5	1/1/0	
	4.6 DC line resistance			
	4.7 Insertion loss (no load)			
	4.4 Voltage proof	5/3/2		
	4.5 Insulation resistance			
	4.8 Discharge resistance ¹⁾ Spares			
1A	4.3.2 Creepage distances and clearances	4/2/1	0	0
	4.9 Robustness of terminations			
	4.10 Resistance to soldering heat ¹⁾			
	4.25 Solvent resistance of the marking ²⁾			
2	4.18 Damp heat, steady state	4/2/1	0	0
3A	4.19 Temperature rise or ⁵⁾	4/2/1	0	0
	4.21.1 Endurance current ^{6) 7)}			
3B	4.20 Impulse voltage ^{10) 11)}	4/2/1	0	0
	4.21.2 Endurance – voltage line terminations/case ¹⁾			
3C	4.20 Impulse voltage ^{10) 11)}	4/2/1	0	0
	4.21.3 Endurance voltage between line terminations ⁷⁾			
7	4.23 Passive flammability ²⁾	see 4.23	0	0
9	4.27 Active flammability ²⁾	see 4.27	0	0
Footnotes: see end of Table 7.				

Table 4 – Sampling plan – Safety and performance tests qualification approval – Assessment level D / DZ

Group	Subclauses and tests		Number of specimens tested per qualification ⁴⁾		Number of permissible non-conforming items per qualification ⁴⁾			
					Per group ⁸⁾		Total	
					D	DZ	D	DZ
0	4.3	Dimensions (gauging)	36/16/9	2/1/1	0			
	4.3	Visual examination						
	4.6	DC line resistance or voltage drop						
	4.7	Insertion loss (no load)						
	4.4	Voltage proof						
	4.5	Insulation resistance						
	4.8	Discharge resistance ¹⁾						
	Spares	8/3/2						
1A	4.3	Dimensions (detail)	4/1/1	0	0			
	4.3.2	Creepage distances and clearances						
	4.9	Robustness of terminations						
	4.10	Resistance to soldering heat ¹⁾						
	4.25	Solvent resistance of the marking ²⁾						
1B	4.26	Component solvent resistance ²⁾	4/1/1	1/0/0	0			
	4.12	Rapid change of temperature						
	4.13	Vibration						
	4.14	Bump or ³⁾						
	4.15	Shock						
1	4.16	Container sealing ²⁾	8/2/2	1/0/0	0	1/0/0	0	
	4.17	Climatic sequence						
2	4.18	Damp heat, steady state	4/2/1	0	0			
	4.19	Temperature rise or ⁵⁾						
3A	4.21.1	Endurance – current ^{6) 7)}	4/2/1	0	0			
	4.20	Impulse voltage ^{10) 11)}						
3B	4.21.2	Endurance-voltage line terminations/case ¹⁾	4/2/1	0	0			
	4.20	Impulse voltage ^{10) 11)}						
3C	4.21.3	Endurance – voltage between line terminations ⁷⁾	4/2/1	0	0			
	4	4.22						Charge/discharge ^{1) 11)}
5	4.7	Insertion loss (load/temperature) ²⁾	4/2/1	0	0			
6	4.24	Current overload ²⁾						4/2/1
7	4.23	Passive flammability ²⁾	see 4.23	0	0			
8	4.11	Solderability ^{1) 9)}	4/2/1	0	0			
9	4.27	Active flammability ²⁾	4/2/1	0	0			
Footnotes: see end of Table 7.								

Table 5 – Lot-by-lot-tests – Assessment level D / DZ

Assessment level D			
Group	Subclauses and tests	Inspection level IL	AQL %
A1	4.3 Visual examination 4.3 Marking 4.3 Dimensions (gauging)	S-4	2,5
A2	4.6 DC line resistance 4.7 Insertion loss (no load) 4.4 Voltage proof (test A only) 4.5 Insulation resistance (test A only) 4.8 Discharge resistance ¹⁾	II	1,0
B1	4.11 Solderability ^{1) 9)}	S-3	2,5
Assessment level DZ			
Group	Subclauses and tests	Inspection level IL	Acceptance number
A1	4.3 Visual examination 4.3 Marking 4.3 Dimensions (gauging)	S-3	0
A2	4.6 DC line resistance 4.7 Insertion loss (no load) 4.4 Voltage proof (Test A only) 4.5 Insulation resistance (Test A only) 4.8 Discharge resistance ¹⁾	S-4	0
B1	4.11 Solderability ^{1) 9)}	S-3	0
Footnotes: see end of Table 7.			

Table 6 – Lot-by-lot test – Safety tests only approval

Subclause and test ¹³⁾	Conditions of test ¹³⁾	Sample size	Requirements ¹³⁾
4.3 Visual examination	Non destructive	100 % ¹⁴⁾	Any marking on the filter shall be legible and correct No permanent breakdown or flashover
4.4 Voltage proof (Test A, B and C ¹⁵⁾)	Method for test C: ¹⁶⁾		
Footnotes: see end of Table 7.			

Table 7 – Periodic tests – Assessment level D / DZ

Group	Periodicity Months	Subclauses and tests	Total sample ⁴⁾	Number of non- conforming items ⁸⁾	
				D	DZ
C1A	6	4.3 Dimensions (detail)	2/1/1	0	0
		4.3.2 Creepage distances and clearances			
C1B	6	4.9 Robustness of terminations	4/1/1	0	0
		4.10 Resistance to soldering heat ¹⁾			
C1	6	4.25 Solvent resistance of the marking ²⁾	6/2/2	1/0/0	0
		4.26 Component solvent resistance ²⁾			
C2	12	4.12 Rapid change of temperature	4/2/1	0	0
C3A	3	4.13 Vibration	2/2/1	0	0
		4.14 Bump or ³⁾			
C3B	3	4.15 Shock	2/2/1	0	0
		4.16 Container sealing ²⁾			
C3C	3	4.17 Climatic sequence	4/2/1	0	0
		4.18 Damp heat, steady state			
C4	12	4.19 Temperature rise or ⁵⁾	2/2/1	0	0
C5	12	4.21.1 Endurance – current ^{6) 7)}	2/2/1	0	0
		4.20 Impulse voltage ¹¹⁾			
C6	12	4.21.2 Endurance – voltage line terminations/case	2/2/1	0	0
		4.20 Impulse voltage ¹¹⁾			
C7	12	4.21.3 Endurance – voltage between line terminations ⁷⁾	4/2/1	0	0
		4.22 Charge/discharge ¹⁾			
C8	12	4.7 Insertion loss ²⁾ (load/temperature)	2/2/1	0	0
C9	12	4.24 Current overload	2/2/1	0	0
C10	12	4.23 Passive flammability ²⁾	see 4.23	0	0
C11	12	4.27 Active flammability ²⁾	see 4.27	0	0

Footnotes to Tables 3, 4, 5, 6 and 7:

- 1) If applicable.
- 2) If required in the detail specification.
- 3) Whichever is required in the detail specification.
- 4) See 3.4.3 for the structural similarities which are necessary before filters may be qualified together. The three numbers in each box of the table indicate in descending order the numbers applicable for specimens within the following current limits:
 - < 16 A
 - ≥ 16 A ... ≤ 80 A
 - > 80 A
 "Current" in this context is the sum of the rated current(s) carried by the leads for the individual phases, N excluded. Where a range is qualified which contains filters within more than one of the current classifications listed above, the number of specimens selected shall be that for the classification in which the majority of the values in the range fall. The numbers in Group 0 exclude the numbers of specimens required for Groups 7 and 8.
- 5) For filters with rated current > 0,5 A only.
- 6) For filters with rated current ≤ 0,5 A.
- 7) See 4.21.4 for the option of combining the tests of Groups 3A and 3C.
- 8) When zero non-conforming items are required and one non-conforming item is obtained, all the tests of the group shall be repeated on a fresh sample and then no further non-conforming items are permitted. This provision is not applicable for Groups 7, 8 and C7, or when the non-conforming items obtained in any group are due to failure of the voltage proof test between line terminations and case. For Tables 3 and 4, the non-conforming item obtained in the first sample shall be counted for the total non-conforming items permitted in the right hand column.
- 9) This test may be carried out on electrically defective filters or detached terminations provided they have received all the processing which would be carried out on a completed filter. Group 0 or Group A tests are omitted for filters intended to be submitted to this test.

- 10) Not applicable to filters with capacitors of Subclasses X3 and Y3.
- 11) The tests of this group or subgroup may be omitted if the capacitors in the filter across which the test voltages will appear are separately encapsulated and have been qualified to a detail specification under IEC 60384-14.
- 12) Total number of non-conforming items of the groups 1 through 8.
- 13) Clause numbers of test and conditions/requirements refer to 4.
- 14) May be carried out as end-of-line testing.
- 15) B or C as applicable.
- 16) To be required in the detail specification.

4 Test and measurement procedures

This Clause supplements the information given in Clause 4 of IEC 60939-1.

4.1 Earth inductors incorporated in filters

Earth inductors incorporated in filters shall meet the requirements of the relevant specification(s). See also 2.2.19 of IEC 60938-1.

4.2 Capacitance and tan δ measurements

Measurements of capacitance and tan δ shall be carried out in accordance with 4.2 in IEC 60384-14.

4.3 Visual examination and check of dimensions

4.3.1 General

The filters shall be visually examined and dimensions checked according to 4.4 in IEC 60939-1.

4.3.2 Creepage distances and clearances

Creepage distances and clearances on the outside of the filter between live parts of different polarity or between live parts and a metal case shall not be less than the appropriate values given in Table 8.

Table 8 – Creepage distances and clearances

Points of measurement	Rated voltage (r.m.s.)							
	$U_R \leq 130 \text{ V}$		$130 \text{ V} < U_R \leq 250 \text{ V}$		$250 \text{ V} < U_R \leq 500 \text{ V}$		$500 \text{ V} < U_R \leq 760 \text{ V}$	
	Creepage distance mm	Clearance mm	Creepage distance mm	Clearance mm	Creepage distance mm	Clearance mm	Creepage distance mm	Clearance mm
Between live parts of different polarity	2,0	1,5	3,0	2,5	4,0	3,0	6,3	5,5
Between live parts and other metal parts over basic insulation	2,0	1,5	4,0	3,0	6,3	5,5	6,3	5,5
Between live parts and other metal parts over reinforced insulation	8,0	8,0	8,0	8,0	8,0	8,0	-	-

Further information may be obtained by reference to the full table in IEC 60335-1. For definitions of basic, double and reinforced insulation see IEC 61140.

Compliance shall be checked by measurement according to the rules laid down in IEC 60335-1 for measurements on the outside of the filter. Additional requirements may be necessary, e.g. for drip-proof and splash-proof filters.

4.4 Voltage proof

See 4.6 of IEC 60939-1 with the following details:

4.4.1 Test circuit for d.c. tests

Unless otherwise specified in the detail specification, R_1 shall be large enough to limit the charging current to 50 mA maximum.

Unless otherwise specified in the detail specification, R_2 shall limit the discharge current to 50 mA maximum.

4.4.2 Applied voltage

The voltages given in Table 9 shall be applied between the measuring points of Table 3 of IEC 60939-1 for a period of 1 min for qualification approval and periodic testing and for a period of 2 s for lot-by-lot quality conformance testing. The time shall be measured from the time when 90 % of the test voltage appears across the test terminals.

The method of applying the test voltage for Test C shall be given in the detail specification. For qualification testing, the foil method of 4.5.2.1 of IEC 60939-1 shall be used.

Attention is drawn to the fact that repetition of the voltage proof test may damage the filter.

Attention is drawn to the fact that for some tests it may be necessary for the detail specification to prescribe that resistors or varistors should be disconnected.

Table 9 – Voltage proof

Type of insulation	Range of rated voltages line/line (Test A) or line/ground (Test B or C)	Test A	Test B or C	
			$C \leq 1 \mu\text{F}$	$C > 1 \mu\text{F}$
Basic	< 150 V	4,3 U_R d.c.	900 V a.c. or 1 260 V d.c.	4,3 U_R d.c.
Basic	≥ 150 V ≤ 300 V		1 500 V a.c. or 2 250 V d.c.	
Basic	> 300 V ≤ 520 V		2 000 V a.c. or 3 000 V d.c.	
Basic	> 520 V ≤ 760 V		3 000 V a.c. or 4 000 V d.c.	
Double or reinforced	≥ 150 V ≤ 300 V		3 000 V a.c. or 4 500 V d.c.	
Double or reinforced	> 300 V ≤ 520 V		4 000 V a.c. or 6 000 V d.c.	
Double or reinforced	> 520 V ≤ 760 V		5 000 V a.c. or 7 500 V d.c.	

NOTE C is the capacitance measured at 1 kHz between the relevant test terminations. All a.c. test voltages are r.m.s. and 50 Hz or 60 Hz, unless otherwise specified in the detail specification.

4.4.3 Requirements

There shall be no permanent breakdown or flash-over during the test period.

4.5 Insulation resistance

See 4.5 of IEC 60939-1 with the following details:

The method of applying the test voltage for Test C shall be given in the detail specification. For qualification testing, the foil method of 4.5.2.1 of IEC 60939-1 shall be used.

4.5.1 Temperature correction

When prescribed in the detail specification, the temperature at which the measurement is made shall be noted. If this temperature differs from 20 °C, a correction shall be made to the measured value by multiplying it by the appropriate correction factor prescribed in the capacitor sectional specification for the relevant dielectric, or given in the detail specification.

4.5.2 Requirements

The insulation resistance shall not be less than the value given in Table 10.

Table 10 – Insulation resistance

Climatic category	Test A		Tests B or C <i>R</i> MΩ
	if <i>C</i> > 0,33 μF <i>RC</i> s	if <i>C</i> ≤ 0,33 μF <i>R</i> MΩ	
- / - / 56	4 000	12 000	12 000
- / - / 21 and - / - / 10	2 000	6 000	6 000

NOTE 1 *C* is the capacitance measured at 1 kHz between the relevant test terminations. All a.c. test voltages are r.m.s. and 50 Hz or 60 Hz, unless otherwise specified in the detail specification.

NOTE 2 Limits more severe and related to a dielectric may be given in the detail specification.

NOTE 3 For filters fitted with a discharge resistor this measurement can only be made with the discharge resistor disconnected. If the discharge resistor cannot be disconnected without the filter being destroyed, the test shall be omitted for lot-by-lot tests; for qualification approval and periodic tests, where the discharge resistor cannot be disconnected without the filter being destroyed, the sample shall consist of filters specially made without discharge resistors.

NOTE 4 For multiple filters comprising of a number of individual filter elements the limit be divided by the number of filter channels.

4.6 DC line resistance or voltage drop at rated current

The detail specification will prescribe which of the following two tests shall be used.

4.6.1 DC line resistance

Using a d.c. measuring method with an applied voltage of less than 10 V, the resistance between any input terminal and the corresponding output terminal shall be measured and shall not exceed the limit prescribed in the detail specification. The detail specification may specify precise points of connection between the terminals and the measuring instrument.

4.6.2 Voltage drop at rated current

A d.c. current equal in value to the r.m.s. value of the rated a.c. current, unless otherwise specified in the detail specification, shall be passed through the filter between all pairs of line terminals where the circuit diagram indicates that there should be continuity.

After thermal stability has been reached (unless the detail specification prescribes measurement at the end of a specified period), the voltage drop shall be measured and shall not exceed the limit prescribed in the detail specification.

4.7 Insertion loss

See 4.7 of IEC 60939-1 with the following details:

Before any measurement of insertion loss on filters containing ceramic capacitors, either before or after conditioning, the filters shall be preconditioned under the following conditions:

Exposure at upper category temperature or at such higher temperature as may be specified in the detail specification, for 1 h, followed by a recovery period of (24 ± 1) h at standard atmospheric conditions for testing (for further information see 4.1 of IEC 60384-9).

For measurements made after conditioning, this preconditioning shall follow the prescribed recovery and all the other final inspections and measurements.

In cases where the capacitive and inductive filter elements are individually accessible, the measurement of the capacitors and inductors may be performed as an alternative to the measurement of the insertion loss.

The detail specification shall specify:

- a) any preconditioning requirements;
- b) the method of insertion loss measurement to be used, including the dimensions influencing the characteristic impedance and electrical length of any jigs used to connect the filter to the measurement system;
- c) whether measurements are made with the filter under no load or under specified load;
- d) whether measurements are made in the asymmetric or symmetric mode;
- e) the terminating impedances;
- f) the frequencies at which measurements are to be made (preferred range: 150 kHz to 30 MHz);
- g) the minimum insertion loss or capacitance and inductance to be achieved at each frequency.

When measurements are made after conditioning, the limit shall be 6 dB less severe than the limit applicable in Group A or Group 0.

The detail specification shall prescribe relevant limits for capacitance (C) and inductance (L) together with relevant frequencies if L and C are measured as alternatives to insertion loss.

4.8 Discharge resistance

See 4.8 of IEC 60939-1.

4.9 Robustness of terminations

See 4.9 of IEC 60939-1 with the following details:

The test method and degree of severity to be used shall be specified in the detail specification.

The test for snap-on or other special terminations shall be specified in the detail specification.

4.10 Resistance to soldering heat

This test is not applicable to filters with flexible insulated leads longer than 50 mm, or to filters with terminations (such as snap-on contacts) not intended to be soldered.

See 4.10 of IEC 60939-1 with the following details:

4.10.1 Test conditions

There shall be no pre-drying.

4.10.2 Intermediate inspection, measurements and requirements

The measurements after this test are the intermediate measurements after the tests of Group 1A and before the remainder of the tests of Group 1.

The filters shall be visually examined according to 4.2. There shall be no visible damage.

The d.c. line resistance or voltage drop shall be measured according to 4.6. The value shall be within the limit prescribed in Group A2 of the detail specification.

4.11 Solderability

This test may be carried out on electrically defective filters or detached terminations provided they have received all the processing which would be carried out on a completed filter.

See 4.11 of IEC 60939-1, with the following details:

4.11.1 Test conditions

Ageing of 4 h dry heat at 155 °C shall be applied unless the detail specification specifies no ageing, or a different ageing procedure is specified in the detail specification.

When method 2 is used, a soldering iron of size A shall be used.

4.11.2 Requirements

See 4.11.2, 4.11.3 and 4.11.4 of IEC 60939-1. When Method 3 is used the soldering time shall be less than 3 s.

4.12 Rapid change of temperature

See 4.12 of IEC 60939-1 with the following details:

Number of cycles: 5

Duration of exposure at the temperature limits:

30 min for mass ≤ 25 g;

3 h for mass > 25 g.

4.12.1 Intermediate inspection

The filters shall be visually examined and there shall be no visible damage.

4.13 Vibration

See 4.13 of IEC 60939-1 with the following details:

4.13.1 Test conditions

Endurance by sweeping shall be applied. The following are preferred severities:

0,75 mm displacement or 98 m/s² whichever is the lower amplitude, over one of the following frequency ranges: 10 Hz to 55 Hz, 10 Hz to 500 Hz, 10 Hz to 2 000 Hz. The preferred duration is 6 h, equally divided over the axes swept.

The detail specification shall prescribe the severity and shall also prescribe the mounting method to be used. For filters with axial leads which are intended to be mounted by the leads, the distance between the body and the mounting point shall be 6 mm ± 1 mm.

4.13.2 Intermediate inspection

The filters shall be visually examined and there shall be no visible damage.

4.14 Bump

The detail specification shall state which of the two alternatives, the bump or the shock test, applies.

See 4.14 of IEC 60939-1 with the following details:

4.14.1 Test conditions

The mounting method and the severity shall be specified in the detail specification.

The following severities are preferred:

Total number of bumps:	1 000	or	4 000
Acceleration:	400 m/s ²		100 m/s ²
or			
Pulse duration:	6 ms		16 ms

4.14.2 Intermediate inspection, measurements and requirements

The measurements after this test are the intermediate measurements after the tests of Group 1B and before the remainder of the tests of Group 1.

The filters shall be visually examined according to 4.2. There shall be no visible damage.

The d.c. line resistance or voltage drop shall be measured according to 4.6. The value shall be within the limit prescribed in Group A2 of the detail specification.

4.15 Shock

The detail specification shall state which of the two alternatives, the bump or the shock test, applies.

See 4.15 of IEC 60939-1 with the following details:

4.15.1 Test conditions

The mounting method and the severity shall be specified in the detail specification.

The severities given in Table 11 are preferred.

Pulse shape: half sine.

Table 11 – Preferred severities

Peak acceleration m/s ²	Corresponding duration of the pulse ms
50	30
300	18
500	11
1 000	6

4.15.2 Intermediate inspection, measurements and requirements

The measurements after this test are the intermediate measurements after the tests of Group 1B and before the remainder of the tests of Group 1.

The filters shall be visually examined according to 4.2. There shall be no visible damage.

The d.c. line resistance or voltage drop shall be measured according to 4.6. The value shall be within the limit prescribed in Group A2 of the detail specification.

4.16 Container sealing

This test is applicable only if prescribed in the detail specification.

See 4.16 of IEC 60939-1 with the following details:

4.16.1 Test conditions

The filters shall be subjected to either Test Qc or to Test Qd of IEC 60068-2-17, as appropriate. Unless otherwise specified in the detail specification, Method 2 shall be used when Test Qc is employed.

4.16.2 Requirements

During or after the test, as applicable, there shall be no evidence of leakage.

4.17 Climatic sequence

See 4.17 of IEC 60939-1 with the following details:

4.17.1 Initial measurements

The initial measurements for the climatic sequence are the measurements made in 4.10.2, 4.14.2 or 4.15.2 as appropriate.

4.17.2 Dry heat

See 4.17.2 of IEC 60939-1 with the following details:

No measurements are required at the upper category temperature.

4.17.3 Damp heat, cyclic, first cycle

See 4.17.3 of IEC 60939-1.

4.17.4 Cold

See 4.17.4 of IEC 60939-1 with the following details:

No measurements are required at the lower category temperature.

4.17.5 Low air pressure

This test is only performed if required in the detail specification. It is not normally specified for mains filters.

See 4.17.5 of IEC 60939-1 with the following details:

The test shall be made at a temperature of 15 °C to 35 °C and a pressure of 8 kPa, unless otherwise specified in the detail specification.

For filters with a rated voltage exceeding 200 V, while still at the specified low air pressure, and during the last 1 min of the test period, the rated voltage shall be applied.

There shall be no permanent breakdown, flashover or harmful deformation of the case.

4.17.6 Damp heat, cyclic, remaining cycles

See 4.17.6 of IEC 60939-1.

4.17.7 Final inspection, measurements and requirements

See 4.17.7 of IEC 60939-1, with the following details:

Recovery shall be for 18 h to 26 h under standard conditions for measurement.

The filters shall be visually examined according to 4.2. There shall be no visible damage and any marking shall be legible.

The voltage proof test according to 4.4 shall be carried out with 66 % of the voltage as specified in Table 9. There shall be no permanent breakdown or flashover.

The insulation resistance shall be measured according to 4.5. The value shall exceed 50 % of the applicable limit given in Table 10.

The d.c. line resistance or voltage drop shall be measured according to 4.6. The value shall be within the limit prescribed in Group A2 of the detail specification.

Within a further 72 h, the insertion loss at no load shall be measured in accordance with 4.7 and shall meet the requirements prescribed in 4.7. This test is not required for safety test only.

4.18 Damp heat, steady state

See 4.18 of IEC 60939-1 with the following details:

4.18.1 Test conditions

No voltage shall be applied unless otherwise specified in the detail specification.

When voltage application is prescribed, U_R shall be applied to one half of the sample and no voltage shall be applied to the other half of the sample.

4.18.2 Final inspection, measurements and requirements

See 4.18.3 of IEC 60939-1 with the following details:

Recovery shall be for 18 h to 26 h under standard conditions for measurement.

The filters shall be visually examined according to 4.2. There shall be no visible damage and any marking shall be legible.

The voltage proof test according to 4.4 shall be carried out with 66 % of the voltage as specified in Table 9. There shall be no permanent breakdown or flashover.

The insulation resistance shall be measured according to 4.5. The values for Test A, B and C shall not be less than 3,5 M Ω .

The d.c. line resistance or voltage drop shall be measured according to 4.6. The value shall be within the limit prescribed in Group A2 of the detail specification.

Within a further 72 h, the insertion loss at no load shall be measured in accordance with 4.7 and shall meet the requirements prescribed in 4.7.

4.19 Temperature rise

This test is applicable only to filters with a rated current >0,5 A. See Tables 3 and 4, footnotes 4, 5 and 6.

The purpose of the test is to show that, when the relevant temperature rise is added to the rated temperature or upper category temperature, the maximum working temperature of the internal insulation (according to the requirements of IEC 60085), or of the inductive, capacitive or resistive elements is not exceeded.

See 4.19 of IEC 60939-1 with the following details:

4.19.1 Test method

If the filter has a non-zero maximum current at upper category temperature, half the specimens shall be tested at the upper category temperature with the maximum current for that temperature and the other half of the specimens shall be tested at the rated temperature with the rated current. If the maximum current at upper category temperature is specified in the detail specification as zero then all the specimens shall be tested at rated temperature with the rated current.

The filters shall be connected to a power in such a way that all lines carry the test current at the same time.

When testing 3-phase-filters, having an additional neutral line, two different test runs shall be carried out:

- a) the test current shall be passed through all three phases ¹, neutral excluded;
- b) the test current shall be passed through two phases and neutral ² (one phase excluded).

The filter shall be placed in a chamber maintained at an ambient temperature within ± 3 °C of the test temperature. The test a.c. current or a d.c. current equal to the r.m.s. value of the test a.c. current shall be applied.

After thermal equilibrium has been reached, the internal temperature of filters with rated current up to 36 A shall be determined by using the resistance method. In addition, the temperature of components such as inductors, capacitors and varistors shall be measured by means of the thermocouple method.

In case of filters with rated current >36 A, the thermocouple method shall be used to determine the temperature of components such as inductors, capacitors and varistors. The resistance method for these filters is optional.

In agreement with the manufacturer, a specially prepared filter equipped with thermocouples may be submitted for testing.

The internal temperature (T_2) at thermal equilibrium shall be calculated from the measured resistance (R_2) between the input and the output terminals at the temperature T_2 and its measured resistance (R_1) at the test chamber temperature at the start of the test (T_1) using the formulae:

$$T_2 = R_2 / R_1 (235 + T_1) - (T_3 - T_1) - 235 \quad (\text{for copper});$$

$$T_2 = R_2 / R_1 (225 + T_1) - (T_3 - T_1) - 225 \quad (\text{for aluminium}).$$

where T_3 is the temperature of the test chamber T_3 at the end of the test and T_1 , T_2 and T_3 are expressed in degrees Celsius.

Where other metals are used for the inductor windings or lead-through elements the appropriate formula shall be stated in the detail specification.

The resistance R_2 is measured either after switching off the supply, or without interruption of the supply by means of the superposition method, which consists of injecting into the winding a d.c. current of low value superposed on the load current.

¹ Covers normal operation.

² Covers the worst case: one phase disconnected.

The temperature of the hottest part of the case shall also be measured, preferably with an attached thermocouple.

In agreement with the manufacturer a specially prepared filter equipped with thermocouple may be submitted for testing.

NOTE As T_2 is intended to be the internal temperature when the filter is operating in an ambient of the rated temperature T_1 , the factor $(T_3 - T_1)$ is introduced to correct for any change of temperature of the ambient temperature which may occur during the course of the test.

4.19.2 Requirements

The requirements are the same for the test carried out at upper category temperature and at rated temperature.

The internal temperature T_2 shall not exceed the temperature specified in the detail specification. The detail specification may not specify a temperature higher than that specified in IEC 60085 for the lowest class of insulation contained within the filter or higher than the upper category temperature of any internal inductive, capacitive or resistive elements.

The temperature of the hottest part of the case shall not exceed the upper category temperature or a higher temperature if this is prescribed in the detail specification.

NOTE If a higher temperature is prescribed, this has implications for the temperature at which the endurance test is carried out. See 4.20.2 and 4.20.3.

4.20 Impulse voltage

This test is to be carried out as a sequence with the endurance test described in 4.21.

4.20.1 Initial measurements

Initial measurements have been made in Group 0 of Table 3 or Table 4.

4.20.2 Test conditions

Filters shall be submitted to an impulse voltage test except for filters with capacitors of subclasses X3 and Y3.

Each individual filter shall be subjected to a maximum of 24 impulses of the same polarity. The time between impulses shall not be less than 10 s. The peak value of the voltage impulse shall be as given in Tables 1 and 2.

The front time t_r is defined as:

$$t_r = (t_{90} - t_{30}) \times 1,67 \text{ according to 18.1.4 of IEC 60060-1.}$$

For the definition of the time to half-value t_d see 18.1.6 of IEC 60060-1.

The waveform will be determined by the test circuit parameters. Details of the test circuit are given in Annex C.

Before use, the functioning of the circuit shall be checked using C_X values of 0,01 μF and 0,1 μF , and the values for the other circuit elements as given in Table C.1. The front time t_r and time to half-value t_d shall be within 0 % + 50 % of the values given in Table C.2. The capacitors C_X used for this check should not be high permittivity ceramic.

If the waveform from the check shows a damped oscillation, the peak-to-peak value of this oscillation, U_{pp} , shall not be greater than 10 % of the peak voltage of the impulse U_{CR} . (see Figure 1).

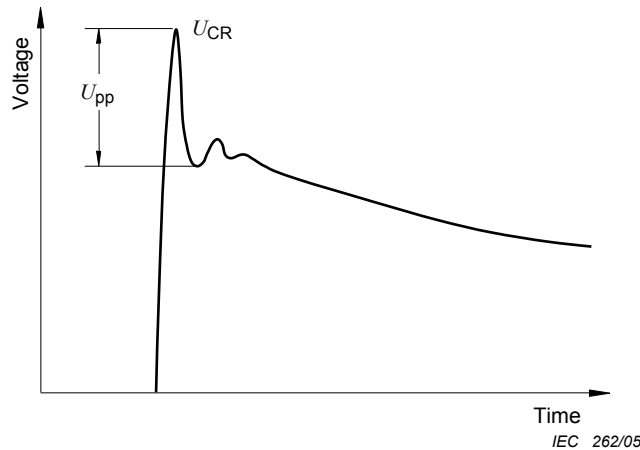

Figure 1 – Impulse wave form

4.20.3 Requirements

There shall be no permanent breakdown or flashover.

If any three successive impulses are shown by the oscilloscope monitor to have had a waveform indicating that no self-healing breakdowns or flashovers have taken place in the filter, then no further impulses shall be applied and the filter shall be counted as conforming.

If all 24 impulses have been applied to the filter and three or more of them are of a waveform indicating that no self-healing breakdowns or flashovers have occurred then the filter shall be counted as conforming, but if less than three impulses are of the required waveform then the filter shall be counted as a non-conforming item.

4.21 Endurance

This test shall be carried out within one week of the completion of the impulse voltage test.

See 4.21 of IEC 60939-1 with the following details:

4.21.1 Test conditions – current test

This test is not applicable to filters with rated current > 0,5 A. See Tables 3 and 4, footnotes 4, 5 and 6.

This test is omitted if a combined voltage/current endurance test is carried out according to 4.21.4.

The filters shall be mounted in the test chamber using such heat-sinking arrangements specified by the detail specification as appropriate for normal use with the filter at the current and temperature specified in the test.

After the chamber has been stabilised at the test temperature, the test current shall be passed through the filters. The frequency of the test current shall be 50 Hz or 60 Hz unless the detail specification specifies that the rated frequency shall be used. If the detail specification specifies a non-zero current at upper category temperature, then half the sample shall be tested at 1,1 times this current at the upper category temperature and half at 1,1 times the rated current at the rated temperature; otherwise the whole sample shall be tested at 1,1 times the rated current at the rated temperature.

NOTE A fuse or other suitable device may be connected in the circuit of each filter to indicate if failure occurs.

After 1 000 h, the filters shall be allowed to recover for 1 h to 26 h and shall then meet the requirements of 4.21.5.

4.21.2 Test conditions – voltage test, terminations/case

This test is not applicable when either the filter case consists of non-conductive material or when one of the line terminations may be considered to be part of the case.

The filters shall be submitted to an endurance test of 1 000 h at the upper category temperature, unless a higher temperature has been specified in 4.19.2, when the endurance test shall be carried out at this higher temperature. The voltage applied shall be $1,7 U_R$ at 50 Hz or 60 Hz, except that once every hour the voltage shall be increased to 1 000 V r.m.s. 50 Hz or 60 Hz for 0,1 s. Each of these voltages shall be applied to each filter individually between the line terminals connected together and the case and earth terminal connected together through a resistor of $47 \Omega \pm 5 \%$. The circuit is shown in Annex D.

The test circuit should be designed so that voltage transients and current surges are avoided during switching. This may be achieved by discharging the capacitance of the filter before switching to the new voltage provided that the total time taken to change over to 1 000 V and back does not exceed 30 s.

NOTE A fuse or other suitable device may be connected in the circuit of each filter to indicate if failure occurs.

After 1 000 h, the filters shall be allowed to recover for 1 h to 26 h and shall then meet the requirements of 4.21.5.

4.21.3 Test conditions – voltage test between terminations

This test is omitted if a combined voltage/current endurance test is carried out according to 4.21.4. The filters shall be submitted to an endurance test of 1 000 h at the upper category temperature, unless a higher temperature has been specified in 4.19.2, when the endurance test shall be carried out at this higher temperature. The voltage applied shall be $1,25 U_R$ at rated frequency, except that once every hour the voltage shall be increased to 1 000 V r.m.s. 50 Hz or 60 Hz (or rated frequency if this is specified in the detail specification) for 0,1 s. Each of these voltages shall be applied to each filter individually across the terminals designed to be connected to the mains supply through a resistor of $47 \Omega \pm 5 \%$. For frequencies of test voltage above 100 Hz a resistor of lower value than 47Ω may be prescribed by the detail specification. The circuit is shown in Annex D.

The test circuit should be designed so that voltage transients and current surges are avoided during switching. This may be achieved by discharging the capacitance of the filter before switching to the new voltage provided that the total time taken to change over to 1 000 V and back does not exceed 30 s.

NOTE A fuse or other suitable device may be connected in the circuit of each filter to indicate if failure occurs.

After 1 000 h, the filters shall be allowed to recover for 1 h to 26 h and shall then meet the requirements of 4.21.5.

4.21.4 Test conditions – combined voltage/current tests

For some types of filter, such as coaxial lead-through filters, it is possible without difficulty to apply both test voltage and current to the filter at the same time. The circuit shall be arranged so that the current is applied continuously during the voltage switching described in Annex D. If prescribed in the detail specification, a combined endurance test of 1 000 h may be carried out instead of the tests of 4.21.1 and 4.21.3 using the number of samples appropriate for the test of 4.21.3. The filters shall be mounted as in 4.21.1. Half of the sample shall be tested at the rated temperature, with 1,1 times the rated current; the other half shall be tested at the upper category temperature, with 1,1 times the specified current at the upper category temperature (which current may be zero). For both halves of the sample, a voltage shall also be applied as prescribed in 4.21.3, if a capacitor of Class X is under test, or as in 4.21.2, if a capacitor of Class Y is under test.

NOTE A fuse or other suitable device may be connected in the circuit of each filter to indicate if failure occurs.

After 1 000 h the filters shall be allowed to recover for 1 h to 26 h and shall then meet the requirements of 4.21.5.

4.21.5 Final inspection, measurements and requirements

The filters shall be visually examined according to 4.2. There shall be no visible damage and any marking shall be legible.

The voltage proof test according to 4.4 shall be carried out with 66 % of the voltage as specified in Table 9. There shall be no permanent breakdown or flashover.

The insulation resistance shall be measured according to 4.5. The value shall exceed 50 % of the applicable limit given in Table 10.

The d.c. line resistance or voltage drop shall be measured according to 4.6. The value shall be within the original limit prescribed in the detail specification.

Within a further 72 h, the insertion loss shall be measured in accordance with 4.7 and shall meet the requirements prescribed in 4.7.

4.22 Charge and discharge

In order to connect the filter as a capacitor, as required for the test, each supply input termination shall be electrically connected to its corresponding output termination, and the measurements made across the supply terminations.

Table 12 – Measurements and requirements after charge and discharge

Inspection or measurement	Inspection or measuring method	Requirement
Capacitance	4.2.2 of IEC 60384-14	The difference between the capacitances measured finally and in 4.22.1 shall not exceed 10 %.
Tan δ for $C \leq 1 \mu\text{F}$ $f = 10 \text{ kHz}$	4.22.1	The increase of tan δ over that measured in 4.22.1 shall not exceed 80×10^{-4} .
Tan δ for $C > 1 \mu\text{F}$ $f = 1 \text{ kHz}$	4.22.1	The increase of tan δ over that measured in 4.22.1 shall not exceed 50×10^{-4} .
Insulation resistance	4.5	Greater than 50 % of the applicable limits of Table 10.

See 4.22 of IEC 60939-1 with the following details:

4.22.1 Initial measurements

The capacitance and $\tan \delta$ shall be measured.

4.22.2 Test conditions

The filters shall be subjected to 10 000 cycles of charge and discharge at the rate of approximately one operation per second.

Each cycle shall consist of charging and discharging the filter. For a.c. rated filters the test voltage shall be

$$\sqrt{2} \times U_R$$

Each filter shall be individually charged by applying the test voltage through a resistor with the value

$$R = (220 \times 10^{-6})/C \quad \Omega$$

or the value required to limit the charge current to 1 A (or to the higher current value given in the detail specification) whichever resistance value is the greater. C is the capacitance in farads measured in 4.22.1.

Each filter shall be individually discharged through a resistor of such a value that the rate of change of voltage (dU/dt) shall not be less than 100 V/ μ s or greater than 130 V/ μ s.

If it is impossible to achieve a discharge rate of 100 V/ μ s because of internal resistance in the filter, the filter shall be discharged through a short circuit.

4.22.3 Final measurements and requirements

The filter connected as a capacitor shall be measured and shall meet the requirements of Table 12.

4.23 Passive flammability

This test is applicable only if prescribed in the detail specification.

See 4.23 of IEC 60939-1.

The initial and final measurements shall be prescribed in the detail specification. The requirements are those given in IEC 60939-1 for the category of flammability prescribed in the detail specification.

4.24 Current overload

This test is applicable only if prescribed in the detail specification.

See 4.20 of IEC 60939-1.

The initial and final measurements shall be prescribed in the detail specification.

4.25 Solvent resistance of the marking

This test is applicable only if prescribed in the detail specification.

See 4.25 of IEC 60939-1.

The requirements are as in 4.25 of IEC 60939-1.

4.26 Component solvent resistance

This test is applicable only if prescribed in the detail specification.

See 4.26 of IEC 60939-1.

The initial and final measurements shall be prescribed in the detail specification.

4.27 Active flammability

This test is applicable only if prescribed in the detail specification.

See 4.24 of IEC 60939-1.

Annex A (normative)

Test schedule for qualification approval – Assessment level D / DZ

Table A.1 – Test schedule for qualification approval – Assessment level D / DZ

Subclause number and test ¹⁾	Conditions of test ¹⁾	Number of specimens (n) and number of non-conforming items (c)	Performance requirements ¹⁾
Group 0	Non destructive	See Table 4	
4.3 Dimensions (gauging)			See detail specification
4.3 Visual examination			No visible damage Legible marking and as specified in the detail specification
4.6 DC line resistance or voltage drop			See detail specification
4.7 Insertion loss (no load)			Within specified tolerance
4.4 Voltage proof	See detail specification for the method		No permanent breakdown or flash-over
4.5 Insulation resistance	See detail specification for the method		As in Table 10
4.8 Discharge resistance ³⁾	See detail specification for the method		Within specified tolerance
Group 1A	Destructive	See Table 4	
4.3 Dimensions (detail)			See detail specification
4.3.2 Creepage distances and clearances			See Table 8
4.9 Robustness of terminations	Severity: see detail specification		No visible damage
4.10 Resistance to soldering heat ³⁾	No pre-drying; see detail specification for the method		
4.25 Solvent resistance of the marking ²⁾			The marking shall remain legible
4.10.2 Intermediate measurements	Visual examination DC line resistance or voltage drop		No visible damage As in Group 0
Group 1B	Destructive	See Table 4	
4.26 Component solvent resistance ²⁾			See detail specification
4.12 Rapid change of temperature	T_A = lower category temperature T_B = upper category temperature Five cycles Duration t = ...		
4.12.1 Intermediate inspection	Visual examination		No visible damage
4.13 Vibration	For mounting method and severity see detail specification		
4.13.2 Intermediate inspection	Visual examination		No visible damage

Subclause number and test ¹⁾	Conditions of test ¹⁾	Number of specimens (n) and number of non-conforming items (c)	Performance requirements ¹⁾
4.14 Bump or 4.15 Shock 4.14.2 Intermediate measurements or 4.15.2	For mounting method and severity see detail specification Visual examination DC line resistance or voltage drop	See Table 4	No visible damage As in Group 0
Group 1 4.16 Container sealing ²⁾ 4.17 Climatic sequence 4.17.1 Initial measurements 4.17.2 Dry heat 4.17.3 Damp heat, cyclic, Test Db, first cycle 4.17.4 Cold 4.17.5 Low air pressure ²⁾ 4.17.6 Damp heat, cyclic, Test Db, remaining cycles 4.17.7 Final inspection and measurements	Destructive Test Qc or Test Qd as prescribed in the detail specification Measurements made in 4.10.2, 4.14.2 or 4.15.2 as appropriate No measurements No measurements Specify severity if non-standard See 4.17.5 for applied voltage Recovery 18 h to 26 h Visual examination Voltage proof at 66 % of value in Table 9 Insulation resistance DC line resistance or voltage drop Insertion loss (no load)	See Table 4	No evidence of leakage No permanent breakdown, flashover or harmful deformation of the case No visible damage Marking legible No permanent breakdown or flashover > 50 % of Table 10 limit As in Group 0 As in 4.7
Group 2 4.18 Damp heat, steady state 4.18.1 Test conditions 4.18.2 Final inspection and measurements	Destructive Specify if applied voltage is required. If so for half the sample U_R applied, for other half no voltage applied Recovery 18 h to 26 h Visual examination Voltage proof at 66 % of value in Table 9 Insulation resistance DC line resistance or voltage drop Insertion loss (no load)	See Table 4	No visible damage Marking legible No permanent breakdown or flashover $\geq 3,5 \text{ M}\Omega$ As in Group 0 As in 4.7

Subclause number and test ¹⁾	Conditions of test ¹⁾	Number of specimens (n) and number of non-conforming items (c)	Performance requirements ¹⁾
Group 3A 4.19 Temperature rise or 4.21.1 Endurance, current	Destructive For filters with rated current > 0,5 A For filters with rated current ≤ 0,5 A Duration: 1 000 h Current and temperature: see 4.21.1	See Table 4	
Group 3B 4.20 Impulse voltage 4.21.2 Endurance voltage, line terminations to case ³⁾	Destructive 3 impulses, full wave Crest voltage: see Tables 1 and 2 Duration: 1 000 h Voltage and temperature: see 4.21.2	See Table 4	See 4.20.3
Group 3C 4.20 Impulse voltage 4.21.3 Endurance voltage between line terminations or 4.21.4 Endurance, combined voltage/current ²⁾	Destructive 3 impulses, full wave Crest voltage: see Tables 1 and 2 Duration: 1 000 h Voltage and temperature: see 4.20.3 Duration: 1 000 h Voltage, temperature and current: see 4.21.4	See Table 4	See 4.20.3
Group 3 4.21.5 Final inspection and measurements for all endurances	Recovery 1 h to 26 h Visual examination Voltage proof at 66 % of value in Table 9 Insulation resistance DC line resistance or voltage drop Insertion loss (no load)	See Table 4	No visible damage No permanent breakdown or flashover > 50 % of Table 10 limit As in Group 0 As in 4.7
Group 4 4.22 Charge and discharge 4.22.1 Initial measurements 4.22.3 Final measurements	Destructive Only for filters containing metallized film and/or metallized paper capacitors Capacitance at 1 kHz Tan δ at 10 kHz for C _R ≤ 1 μF 1 kHz for C _R > 1 μF Capacitance Tan δ at same frequency as initial measurement Insulation resistance	See Table 4	Recorded for reference Recorded for reference See Table 12 See Table 12 See Table 12
Group 5 4.7 Insertion loss (load/temperature) ²⁾	Non destructive See detail specification for method, temperature and load current	See Table 4	See detail specification

Subclause number and test ¹⁾	Conditions of test ¹⁾	Number of specimens (n) and number of non-conforming items (c)	Performance requirements ¹⁾
Group 6 4.24 Current overload ²⁾	Destructive Mounting as specified in the detail specification	See Table 4	See detail specification
Group 7 4.23 Passive flammability ²⁾	Destructive	See Table 4	According to specified category in the detail specification
Group 8 4.11 Solderability ³⁾	Destructive Specify ageing if none or other than 4 h, 155 °C dry heat. For method see detail specification	See Table 4	Methods 1 and 2: good tinning Method 3: < 3 s
Group 9 4.27 Active flammability ²⁾	Destructive	See Table 4	See detail specification
¹⁾ Subclause numbers of test and performance requirements refer to Clause 4 of this Sectional specification. ²⁾ If required in the detail specification. ³⁾ If applicable. See Note 11 to Table 7 for the applicability of Groups 3B and 3C.			

Annex B
(normative)
Test schedule for safety requirements only

Table B.1 – Test schedule for safety requirements only

Subclause number and test ¹⁾	Conditions of test ¹⁾	Number of specimens (n) and number of non-conforming items (c)	Performance requirements ¹⁾
Group 0	Non destructive	See Table 3	
4.3 Visual examination			No visible damage Legible marking and as specified in the detail specification
4.6 DC line resistance or voltage drop			See detail specification
4.7 Insertion loss (no load)			Within specified tolerance
4.4 Voltage proof	See detail specification for the method		No permanent breakdown or flashover
4.5 Insulation resistance	See detail specification for the method		As Table 10
4.8 Discharge resistance ³⁾	See detail specification for the method		Within specified tolerances
Group 1A	Destructive	See Table 3	
4.3.2 Creepage distances and clearances			See Table 8
4.9 Robustness of terminations	Severity: see detail specification		No visible damage
4.10 Resistance to soldering heat ³⁾	No pre-drying See detail specification for the method		
4.25 Solvent resistance of the marking ²⁾	Recovery: 1 h to 26 h		The marking shall remain legible
4.17.7 Final inspection and measurements	Visual examination Voltage proof at 66 % of value in Table 9 Insulation resistance DC line resistance or voltage drop		No visible damage Marking legible No permanent breakdown or flashover > 50 % of Table 10 limit As in Group 0
Group 2	Destructive	See Table 3	
4.18 Damp heat, steady state			
4.18.1 Test conditions	Specify if applied voltage is required. If so for half the sample U_R applied, for other half no voltage applied Recovery 18 h to 26 h		
4.18.2 Final inspection	Visual examination Voltage proof at 66 % of value in Table 9 Insulation resistance DC resistance or voltage drop Insertion loss (no load)		No visible damage Marking legible No permanent breakdown or flashover $\geq 3,5 \text{ M}\Omega$ As in Group 0 As in 4.7

Subclause number and test ¹⁾	Conditions of test ¹⁾	Number of specimens (n) and number of non-conforming items (c)	Performance requirements ¹⁾
Group 3A 4.19 Temperature rise or 4.21.1 Endurance, current	Destructive For filters with rated current > 0,5 A For filters with rated current ≤ 0,5 A Duration: 1 000 h Current and temperature: see 4.21.1	See Table 3	
Group 3B 4.20 Impulse voltage 4.21.2 Endurance, voltage, line terminations to case ³⁾	Destructive 3 impulses, full wave Crest voltage: see Tables 1 and 2 Duration: 1 000 h Voltage and temperature: see 4.21.2	See Table 3	See 4.20.3
Group 3C 4.20 Impulse voltage 4.21.3 Endurance, voltage, between line terminations or 4.21.4 Endurance, combined voltage/current ²⁾	Destructive 3 impulses, full wave Crest voltage: see Tables 1 and 2 Duration: 1 000 h Voltage and temperature: see 4.21.3 Duration: 1 000 h Voltage, temperature and current: see 4.21.4	See Table 3	See 4.20.3
Group 3 4.21.5 Final inspection and measurements for all endurance tests	Recovery: 1 h to 26 h Visual examination Voltage proof at 66 % of value in Table 9 Insulation resistance DC line resistance or voltage drop Insertion loss (no load)	See Table 3	No visible damage No permanent breakdown or flashover > 50 % of Table 10 limit As in Group 0 As in 4.7
Group 7 4.23 Passive flammability ²⁾	Destructive If prescribed in the detail specification	See Table 3	See 4.23
Group 9 4.27 Active flammability ²⁾	Destructive If prescribed in the detail specification	See Table 3	See 4.27
¹⁾ Subclause numbers of test and performance requirements refer to Clause 4 of this Sectional specification. ²⁾ If required in the detail specification. ³⁾ If applicable. See Note 11 to Table 7 for the applicability of Groups 3B and 3C.			

Annex C (normative)

Circuit for the impulse voltage test

The test prescribed in 4.20 shall be carried out using the circuit of Figure C.1.

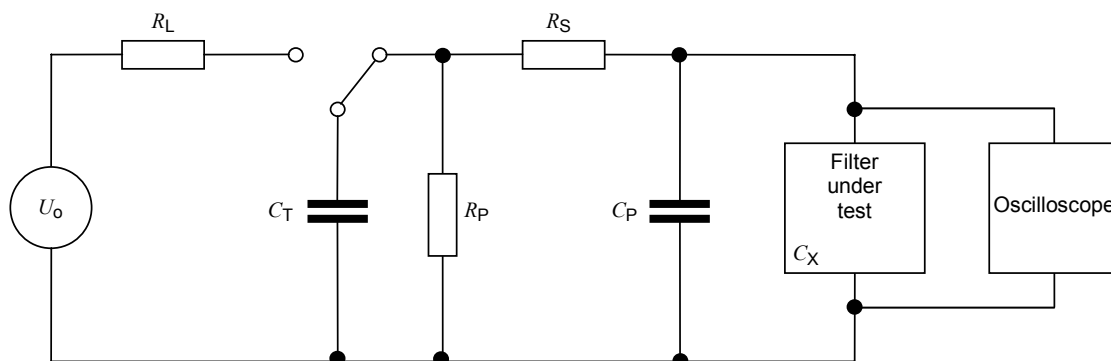

IEC 263/05

- C_T charging (or tank) capacitor
- C_P the parallel capacitor
- C_X the capacitance of the filter under test, measured at 1 kHz across the terminals to which the impulses are to be applied, all other terminals being disconnected
- R_L the loading resistor
- R_S the series resistor, or charging resistor
- R_P the parallel resistor, or discharging resistor
- U_o the direct voltage source

Figure C.1 – Impulse voltage test circuit

Table C.1 – Values of C_X , C_T , R_P , R_S , C_P

C_X μF	C_T $\pm 10\%$ μF	R_P $\pm 10\%$ Ω	R_S $\pm 10\%$ Ω	C_P $\pm 10\%$ pF
$C_X \leq 0,0039$	0,25	234	62	7 800
$0,0039 < C_X \leq 0,012$	0,25	234	45	7 800
$0,012 < C_X \leq 0,018$	0,25	234	27	7 800
$0,018 < C_X \leq 0,027$	0,25	234	27	-
$0,027 < C_X \leq 0,039$	20	3	25	3 300
$0,039 < C_X \leq 0,056$	20	3	13	3 300
$0,056 < C_X \leq 0,082$	20	3	9	3 300
$0,082 < C_X \leq 0,12$	20	3	7	3 300
$0,12 < C_X \leq 0,18$	20	3	5	3 300
$C_X > 0,18$	20	3	3	3 300

Before use, the functioning of the circuit shall be checked using test capacitors of C_X values either 0,01 μF or 0,1 μF with a tolerance of $\pm 2\%$ and corresponding values for the other circuit elements as given in Table C.1. The front time t_r and time to half-value t_d shall be as indicated in Table C.2.

Table C.2 – Values and tolerances of C_X , t_r , t_d

C_X ± 2 % μF	t_r (0/+50) % μs	t_d (0/+50) % μs
0,01	1,7	46
0,1	1,6	47

Annex D (normative)

Circuit for the endurance test

The test prescribed in 4.22.2 and 4.22.3 shall be carried out with the circuit shown in Figure D.1.

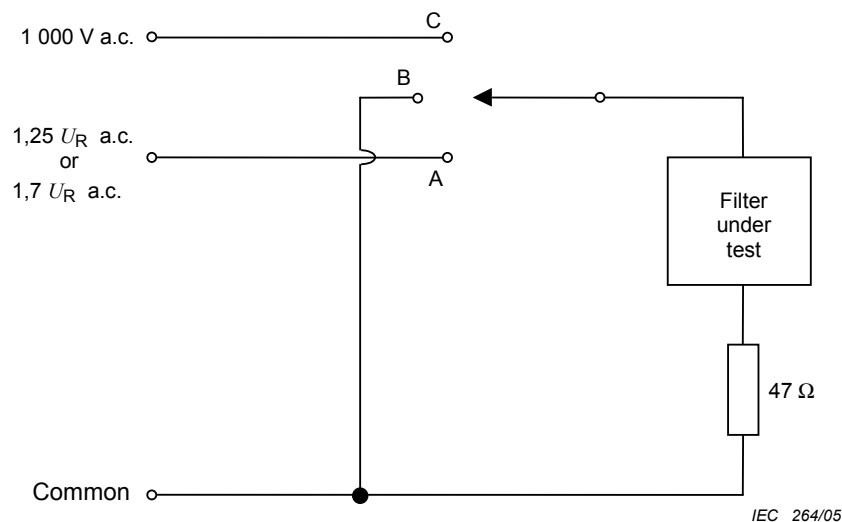

Figure D.1 – Endurance test circuit

The part of the circuit for discharging the filter may be omitted if the switching between the two supplies is arranged to take place at the zero voltage point on the sinusoidal wave.

When the discharging circuit is used, the switching shall be arranged in the following sequence for each occasion when the 1 000 V is applied:

- a) Switch from position A to position B. Time for switching and remaining on position B is t_1 .
- b) Switch from position B to position C. Time for switching and remaining on position C is t_2 . Time on position C is 0,1 s.
- c) Switch from position C to position B. Time for switching and remaining on position B is t_3 .
- d) Switch from position B to position A. Time for switching is t_4 .

For any filter under test the following condition must be fulfilled:

$$t_1 + t_2 + t_3 + t_4 \leq 30 \text{ s.}$$

Annex E (normative)

Declaration of design

(Confidential to the manufacturer and the certification body)

The purpose of this description is to register essential data and the basic design of the filters for which approval is sought. The completed form shall be submitted to the relevant certification body prior to any approval testings; its circulation to the other parties is left to the decision of the manufacturer.

Changes of the declared design are permitted only after notifying the certification body in writing.

In this case, the certifying body and the manufacturer shall agree upon necessary steps to be taken.

Registration number:
(to be allocated by the certifying body)

- 1 Applicant:
- 2 Manufacturer:
- 3 Manufacturing site:
- 4 Type designation:
- 5 Circuit diagram:
- 6 Identification of incorporated components:
- 6.1 Capacitor(s):
- 6.2 Choke(s):
- 6.3 Discharge resistor(s):
- 7 Identification of materials:
- 7.1 Case:
- 7.2 Lid:
- 7.3 Filler: ...
- 8 Construction details:

Location	Date	Name	Signature
----------	------	------	-----------

LICENSED TO MECON Limited. - RANCHI/BANGALORE
FOR INTERNAL USE AT THIS LOCATION ONLY, SUPPLIED BY BOOK SUPPLY BUREAU.



Standards Survey

The IEC would like to offer you the best quality standards possible. To make sure that we continue to meet your needs, your feedback is essential. Would you please take a minute to answer the questions overleaf and fax them to us at +41 22 919 03 00 or mail them to the address below. Thank you!

Customer Service Centre (CSC)

International Electrotechnical Commission

3, rue de Varembé
1211 Genève 20
Switzerland

or

Fax to: **IEC/CSC** at +41 22 919 03 00

Thank you for your contribution to the standards-making process.

A Prioritaire

Nicht frankieren
Ne pas affranchir



Non affrancare
No stamp required

RÉPONSE PAYÉE

SUISSE

Customer Service Centre (CSC)
International Electrotechnical Commission
3, rue de Varembé
1211 GENEVA 20
Switzerland



Q1 Please report on **ONE STANDARD** and **ONE STANDARD ONLY**. Enter the exact number of the standard: (e.g. 60601-1-1)

.....

Q2 Please tell us in what capacity(ies) you bought the standard (tick all that apply). I am the/a:

- purchasing agent
- librarian
- researcher
- design engineer
- safety engineer
- testing engineer
- marketing specialist
- other.....

Q3 I work for/in/as a: (tick all that apply)

- manufacturing
- consultant
- government
- test/certification facility
- public utility
- education
- military
- other.....

Q4 This standard will be used for: (tick all that apply)

- general reference
- product research
- product design/development
- specifications
- tenders
- quality assessment
- certification
- technical documentation
- thesis
- manufacturing
- other.....

Q5 This standard meets my needs: (tick one)

- not at all
- nearly
- fairly well
- exactly

Q6 If you ticked NOT AT ALL in Question 5 the reason is: (tick all that apply)

- standard is out of date
- standard is incomplete
- standard is too academic
- standard is too superficial
- title is misleading
- I made the wrong choice
- other

Q7 Please assess the standard in the following categories, using the numbers:

- (1) unacceptable,
- (2) below average,
- (3) average,
- (4) above average,
- (5) exceptional,
- (6) not applicable

- timeliness.....
- quality of writing.....
- technical contents.....
- logic of arrangement of contents
- tables, charts, graphs, figures.....
- other

Q8 I read/use the: (tick one)

- French text only
- English text only
- both English and French texts

Q9 Please share any comment on any aspect of the IEC that you would like us to know:

.....



LICENSED TO MECON Limited. - RANCHI/BANGALORE
FOR INTERNAL USE AT THIS LOCATION ONLY, SUPPLIED BY BOOK SUPPLY BUREAU.

ISBN 2-8318-7857-8



9 782831 878577

ICS 31.160
